

DFD2-Heath for SB-303 instructions.

After completing assembly, carefully inspect all of your solder connections, and the polarity of the diodes, voltage regulator, the electrolytic capacitor, and the IC's.

Adjust the contrast control fully counter-clockwise. Apply power from 8 to 18VDC. You should see some frequency displayed. Adjust the contrast control for the desired effect. Adjust the coarse and fine trim-pots until the IF frequency of your unit is displayed. (Custom micro-controllers have this value pre-stored and it should be displayed). It is best to remove the 4046 chips during setting of the offset to prevent noise from triggering the inputs.

Install the zero ohm jumpers on the four post header on the counter board

The top zero ohm jumper selects 100Hz resolution (jumper off) or 10Hz resolution (jumper on)

The bottom zero ohm jumper selects display format (where USB is used as an example of the operating mode display):

10 Hz resolution: 12.345.67MHz USB (jumper off) or 12.345.670 USB (jumper on)

100Hz resolution: 12.345.6 MHz USB (jumper off) or 12.345.600 USB (jumper on)













Using the LED back-lit display [\(see diagram below\)](#)



The back-lit module has a block of LEDs behind the LCD display. It is powered from terminals A (anode) and K (cathode) with A being plus and K being minus (usually ground). The voltage drop across the LEDs is 4VDC. The current can range from 20ma. To 150ma. The dropping resistor required is $R = (V-4)/I$ where I is the desired current and V is the supply voltage.

One method that works well is to power it from the 78L05 regulator on DFD2 as follows:

On top of the display module, solder an insulated jumper wire from pin 1 (ground) to pin 16. Solder a 33ohm 1/8watt resistor from pin 2 (+5VDC) to pin 15. This supplies 30ma which is about as bright as a car radio dial at night.

PARTS LIST

D1, D2, D3, D4, D5, D6	1N4148		U1, U2, U3	74HC4046	
R1	100ohms Brown-black-brown		U4	74HC153	
R2, R3	1000 ohms brown-black-red		U5	PIC16C71 Labeled according To the model DFD2	
R5, R6	10K 15 turn trimpot not supplied with custom units.		U6	78L05 Voltage regulator	
R4	10K trimpot contrast control adjust fully CCW		U7	20MHz TCXO	
	25 Turn trimpot value may vary		H1	2 pin header 2 Pin jumper	

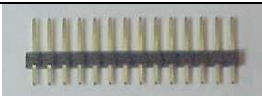
C1, C2, C3 C4, C5, C6 C7, C8, C11	.1uF C1, 4 and 6 Mislabeled on schematic		J1	Female connector	
C12	10uF		P1	Male connector	

Use pins 1-14 of the display module. If 16 pins are available, last two are not used. Backlit option is powered by supplying current (a current limiting resistor **MUST** be used) from the A(anode) to K(cathode) connections on the edge of the module. **See schematic for details.**



DFD2 assembly instructions.

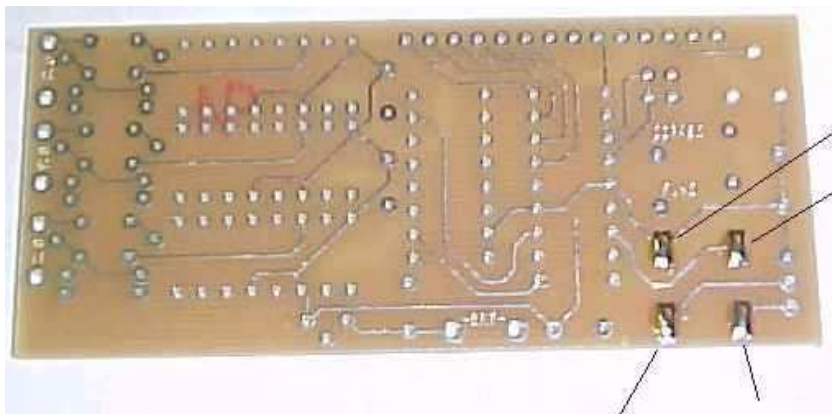

Begin by placing solder globs on the four rectangular pads for the surface mount TCXO.

If I pre-installed the TCXO, I could not test it. If unit displays only 8 black squares then check and reflow the solder on its four corners.

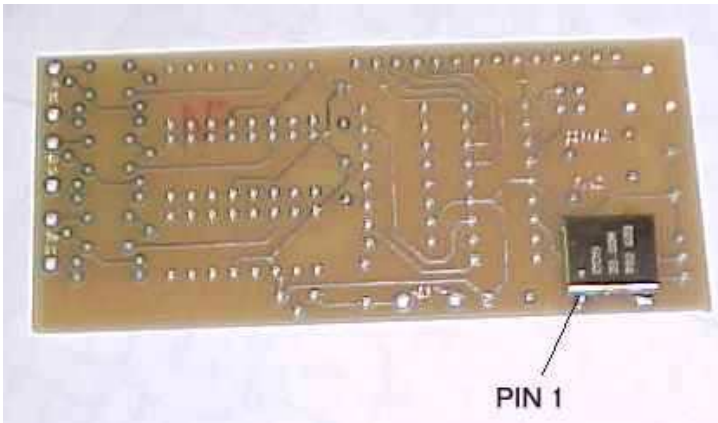

Carefully Position the TCXO with pin 1 as shown and remelt the solder globs while pushing down on that side of the device until all four pads of the TCXO are soldered. You can check by looking at the edge view to verify that solder has flowed onto the TCXO terminals. If later the unit shows only 8 black squares on the display it may be because one or more of these terminals did not properly re-flow solder.

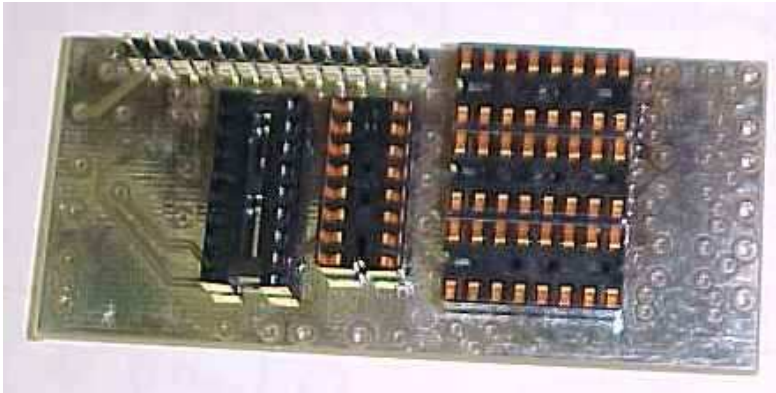

Next mount the IC sockets and display header.

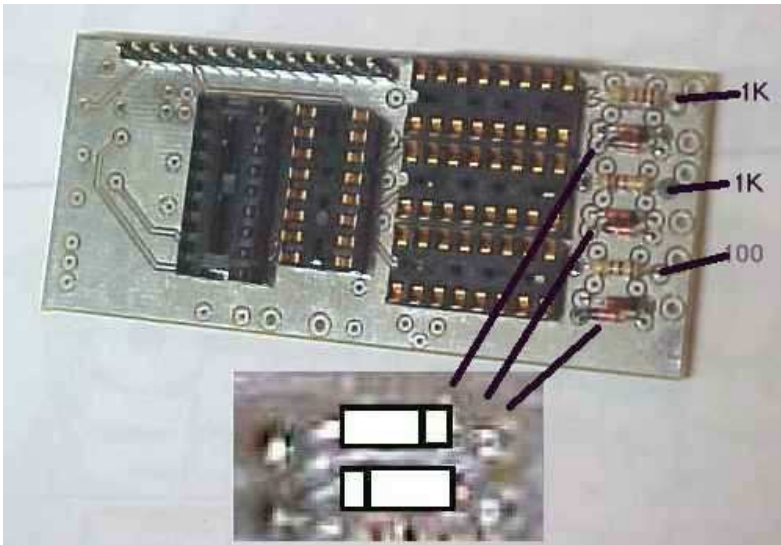

Next install and solder all resistors and the six back to back diodes.

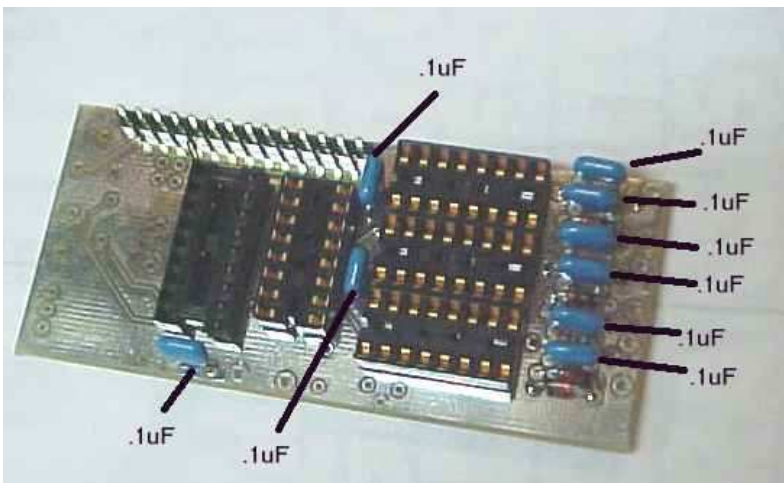

Then install and solder 9 each .1 uF capacitors **Caps can be blue or brown.**

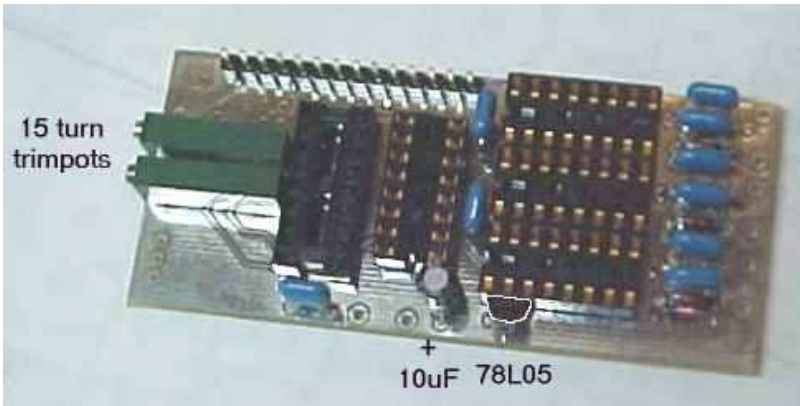

Next install the 78L05 voltage regulator, the 10uF capacitor

+ Terminal of 10uF electrolytic in hole closest to edge of PCB. Flat side of 78L05 toward IC sockets.

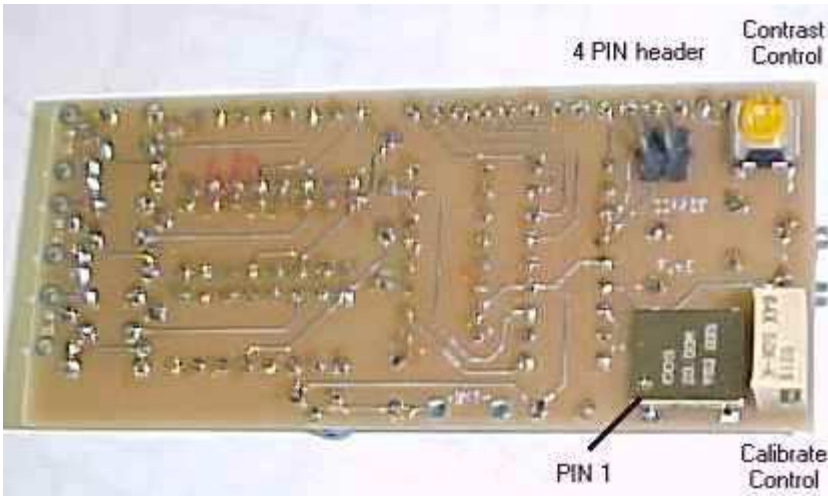

On the back side of the PCB install and solder the 25K calibration control and 10K contrast control (**adjust it fully CCW**)

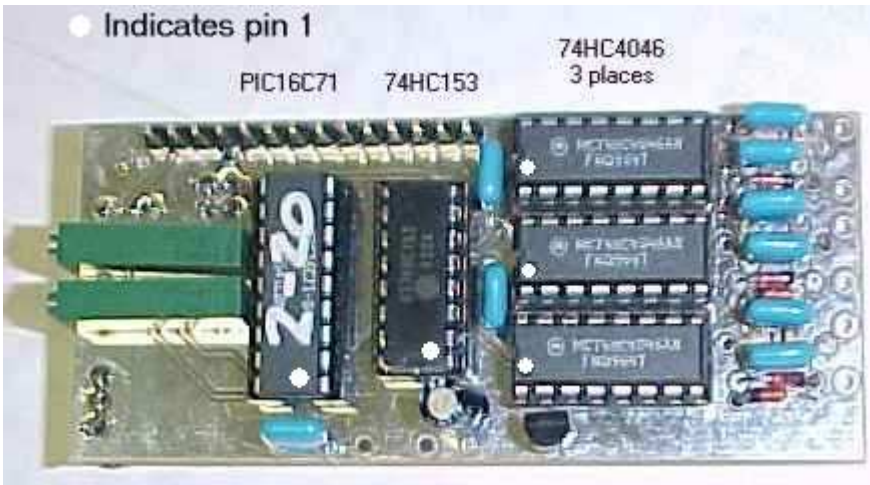

Next, Install the ICs

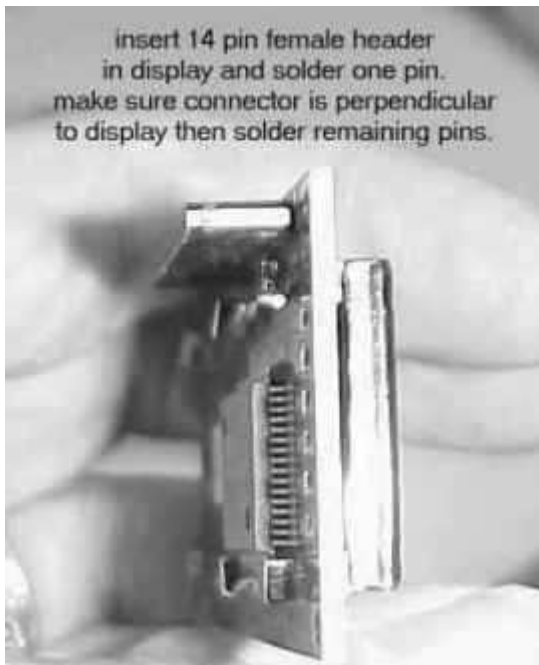

Mount the 14 pin female header on the display module soldering only one pin. Then verify the connector is at a right angle to the module, remelting the soldered pin and adjusting the connector if necessary.

Then solder the remaining pins.

Plug the module into the DFD2 PCB.

At this point you can plug the counter board into the module and power them with a 9 volt battery.

You should see something displayed.

What you see at this point is not important as some inputs are still floating until final assembly in your enclosure.

If only 8 black squares appear, either the TCXO has not been soldered on all 4 points or there is a solder problem on the circuits between the 18 pin chip and the display connector, or on the display module connector.

CALIBRATION

- There are many ways to calibrate a frequency counter depending on available test equipment.
- The simplest is to zero beat a signal generator against WWV (receiver bfo off) while measuring the generator's frequency with the counter.
 - Adjust the 25 turn trimpot on the back of the PCB to obtain the WWV frequency (20 MHz) on the counter's display.
 - Or listen to TCXO on receiver while zero beating it to WWV on 20MHz.
- Any other KNOWN frequency can also be used.

Installation

It is possible to overdrive the inputs causing erratic frequencies to be displayed. A 10K trimpot can be used to set the levels going into the DFD2.

the levels should be set only slightly greater than required for a stable display. Set the BFO input first, then the VFO and finally the HFO (usually on 10mtr band).

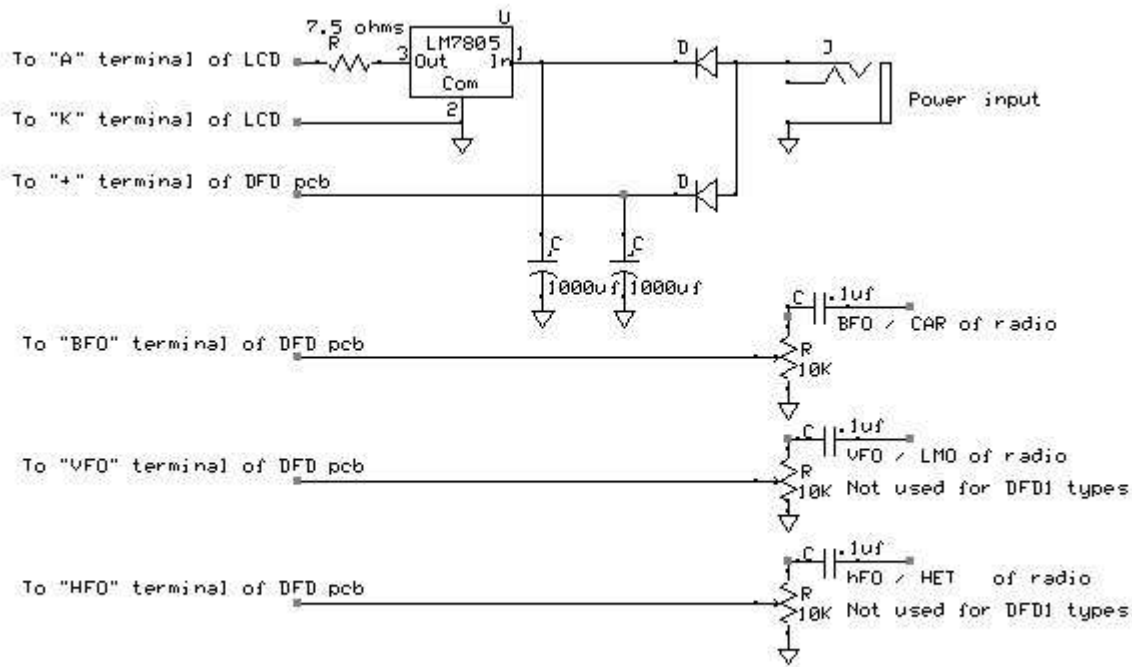

Power Conditioning module for DFD1 and DFD2 applications

This is the power conditioning module supplied as part of the plug-n-play fully assembled digital dials. Something similar is recommended for DFD2 applications to provide level controls.

Only one input is required for a DFD1.

The 7805 part is to power a backlit display option.

**For additional installation hints see
<http://www.aade.com/applications2/app2.html>**

Digital Frequency Display 2

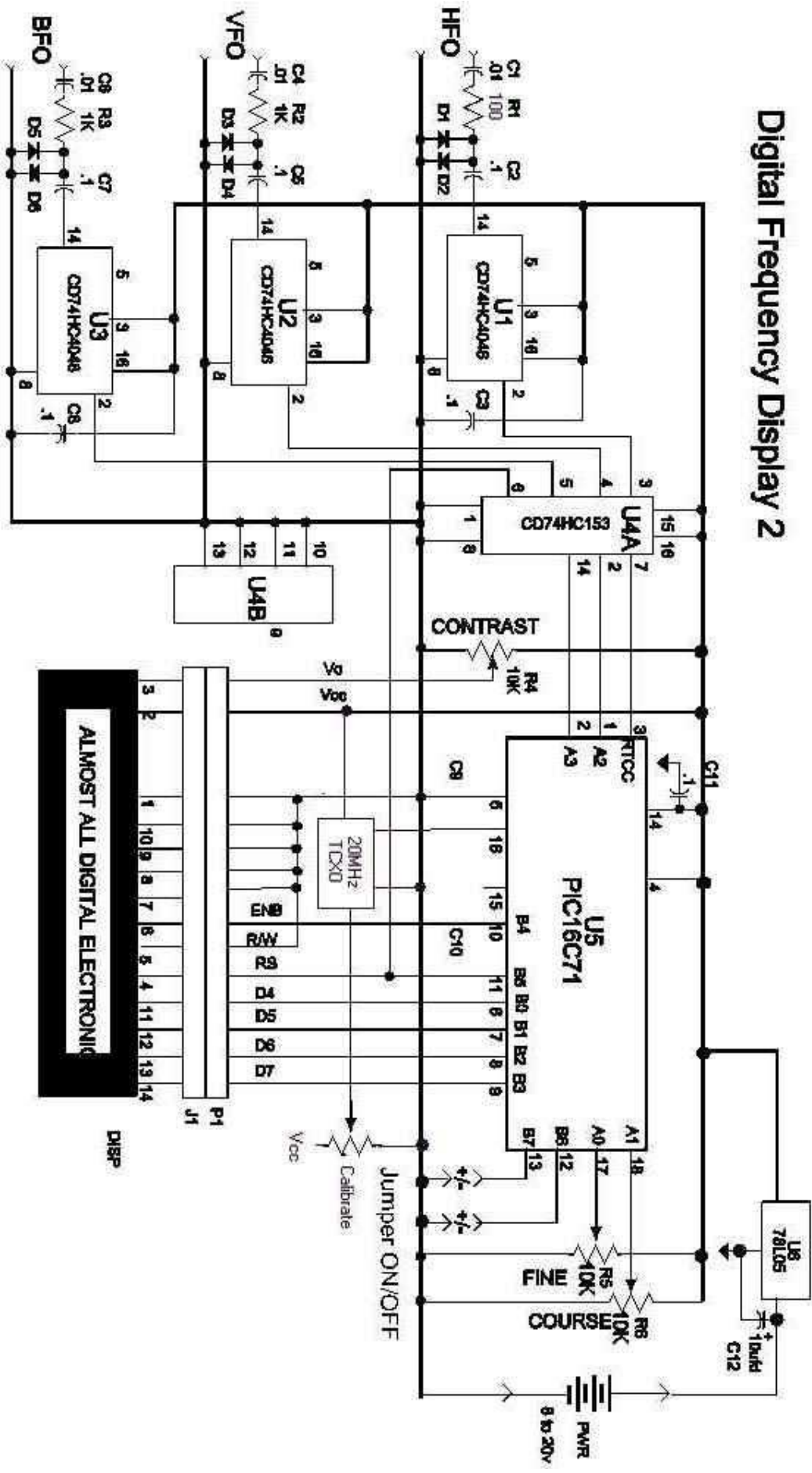

NOTES ON INSTALLING A ADDE DFD2-301 DISPLAY IN A SB-303

The objective is to install a DFD2 display in a Heathkit SB-303 where the zero set scale assembly is located.

I purchased a DFD2-301 kit with the back light option. Paid via Paypal; the kit arrived very quickly. The assembly was fairly straightforward. Could have used a magnifier during the soldering assembly. The assembly is for people with a steady hand and good eyesight. Otherwise get the already assembled option. The only problem I had was after assembly and initially tested, there was no display. I found that the contrast pot needed to be turned fully CCW and then all was OK.

I connected the backlight as suggested in the instructions, using a jumper from pin 1 to pin 16 and soldering a 33 ohm, 1/8 watt resistor from pins 2 to 15. This powers it from the 78L05 regulator.

I removed the zero set scale assembly and nylon follower from the SB-303; I did not remove the front panel. I found that there was not enough room to install the display in the vacant space. I removed the LMO and extended the mounting slots another 3mm to the rear. When moving the LMO to the rear I found an interference with a 6-32 screw in the rear. I replaced the screw with a 4-40 and did a little filing on the corner of the LMO. The proper way would be to move the screw about 3mm to the right (LFF-looking from front). Of course, the main dial needs to be loosened and moved to the front by the amount the LMO was moved to the rear.

I was then able to mount the display on the plastic dial window. This was accomplished by rotating the windows 180 degrees so that the white numbers are now on top. I drilled two 7/64" holes very close to the top to accommodate two 4-40. These line up with two of the holes in the top of the display (these holes were a little small, so they also got the 7/64 drill). 5/16" spacers were inserted between the dial window and the display. The window was then mounted to the dial pointer mounting bracket via the two holes already in the plastic window. In the end, I had to put some spacer washers between the plastic window and the mounting bracket.

It was a tight fit but I was able to mount the display. I installed insulating material on the LMO where the display might hit it. I removed the speed nut that is on the left side of the LMO (LFF) because it hit the logic board. I ran LMO, BFO and HFO cables to the rear panel and plugged them in using RCA plugs. Connecting to the SB-303 +10vdc provided DC power. Some of the metal from the display does show. This can either be painted or left as is; I covered it with black electrical tape.

The display gives the proper frequency readout and indicates USB/LSB/CW/AM. I found it necessary to install the level control circuitry as described by AADE.

I believe that the installation can be done without moving the LMO to the rear by only mounting the display and remotely mounting the logic board. The inter connection can be made via ribbon cable. This may also allow the display to be mounted in the SB-401/301/101.

This could use an AMP/Tyco flat ribbon extension available from digi-key, catalog page <http://dkc3.digikey.com/PDF/T052/0048.pdf>

