

DFD2-101 instructions.

After completing assembly, carefully inspect all of your solder connections, and the polarity of the diodes, voltage regulator, the electrolytic capacitor, and the IC's.

Adjust the contrast control fully counter-clockwise. Apply power from 8 to 18VDC. You should see some frequency displayed. Adjust the contrast control for the desired effect.

The top zero ohm jumper selects 100Hz resolution (jumper off) or 10Hz resolution (jumper on)

The bottom zero ohm jumper selects display format (where USB is used as an example of the operating mode display):













10 Hz resolution: 12.345.67MHz USB (jumper off) or 12.345.670 USB (jumper on)

100Hz resolution: 12.345.6 MHz USB (jumper off) or 12.345.600 USB (jumper on)

Using the LED back-lit display (see diagram below)

The back-lit module has a block of LEDs behind the LCD display. It is powered from terminals A (anode) and K (cathode) with A being plus and K being minus (usually ground). The voltage drop across the LEDs is 4VDC. The current can range from 20ma. To 150ma. The dropping resistor required is $R = (V-4)/I$ where I is the desired current and V is the supply voltage.

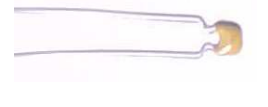
PARTS LIST

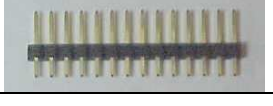
D1, D2, D3, D4, D5, D6	1N4148		U1, U2, U3	74HC4046	
R1	100ohms Brown-black-brown		U4	74HC153	
R2, R3	1000 ohms brown-black-red		U5	PIC16C71 Labeled according To the model DFD2	
			U6	78L05 Voltage regulator	
R4	10K trimpot contrast control adjust fully CCW		U7	20MHz TCXO	
	25 Turn trimpot value may vary		H1	2 pin header 2 Pin jumper	
C1, C2, C3 C4, C5, C6 C7, C8, C11	.1uF C1, 4 and 6 Mislabeled on schematic		J1	Female connector	
C12	10uF		P1	Male connector	

Use pins 1-14 of the display module. If 16 pins are available, last two are not used. Backlit option is powered by supplying current (a current limiting resistor **MUST** be used) from the A(anode) to K(cathode) connections on the edge of the module. **See schematic for details.**

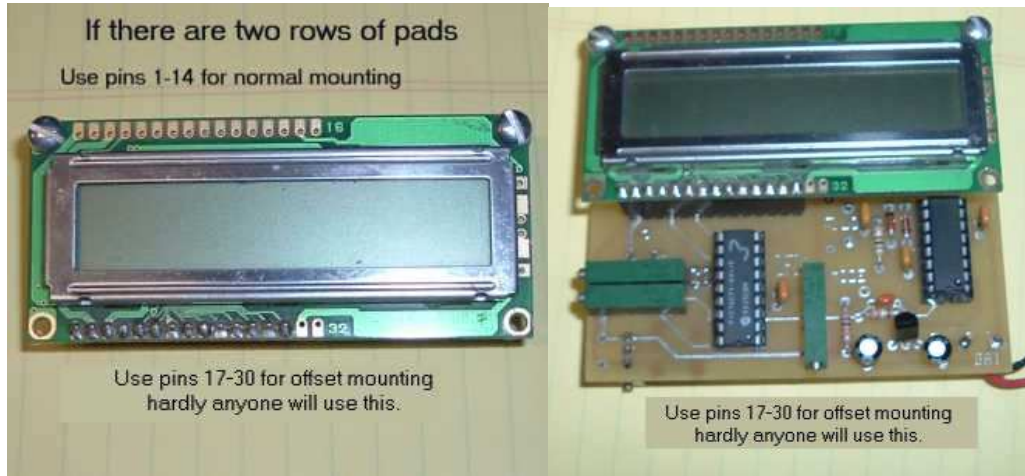

DFD2 assembly instructions.

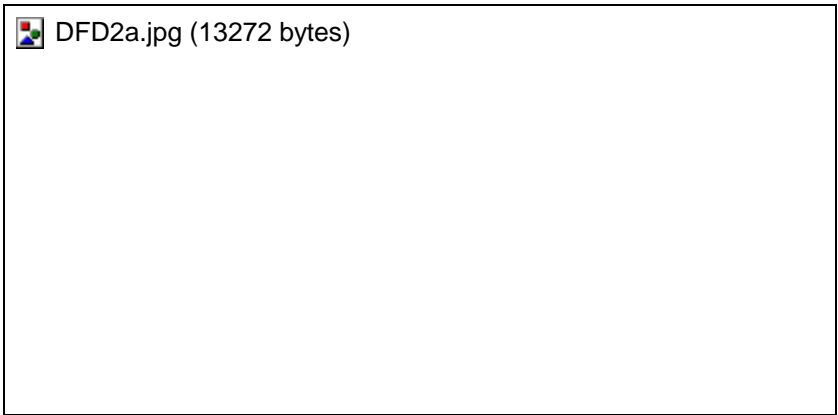

Be
pl
so
gl
the
rect
pads
su
m
TC
If I
ins
t
TC
cou
test
u
dis
on
b
sq
t
cl
a
re
t

sold
its
con

Care
Posi
the 7
with
as sh
and
the s
glob
push
dow
that
the c
until
four
of th
TCX
sold
You
chec
look
the e
view
verif
sold
flow
onto
TCX
term
If lat
unit
only
blac
squa
the c
it ma
beca
one
more
thes
term
did n
prop
reflo
sold

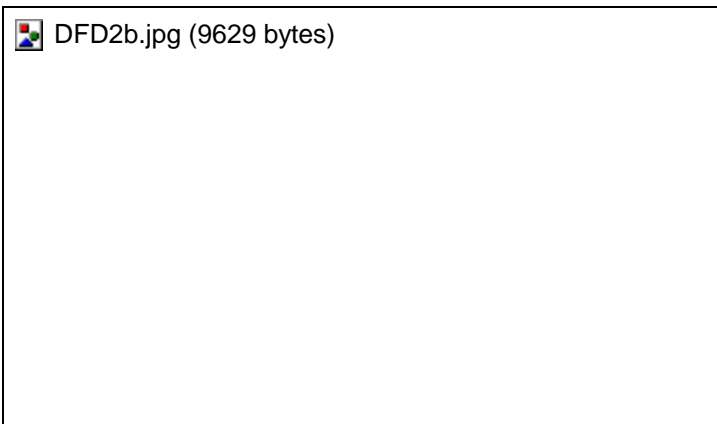

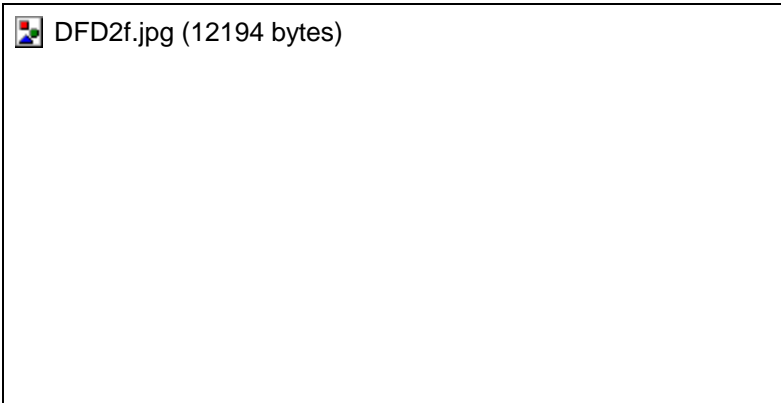
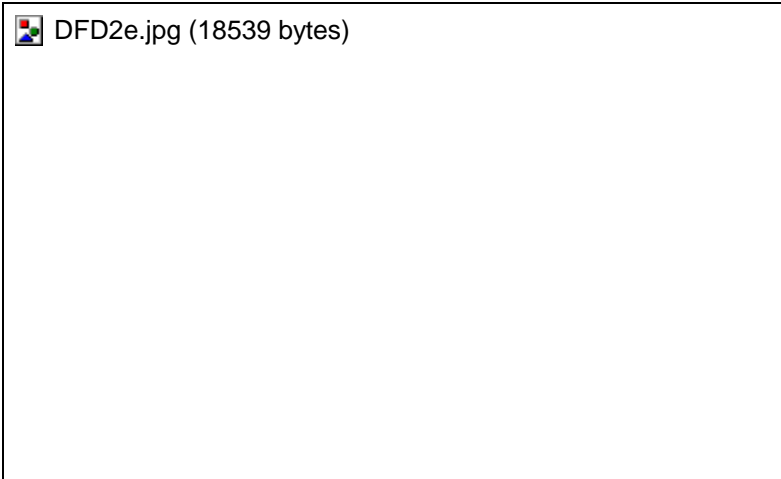
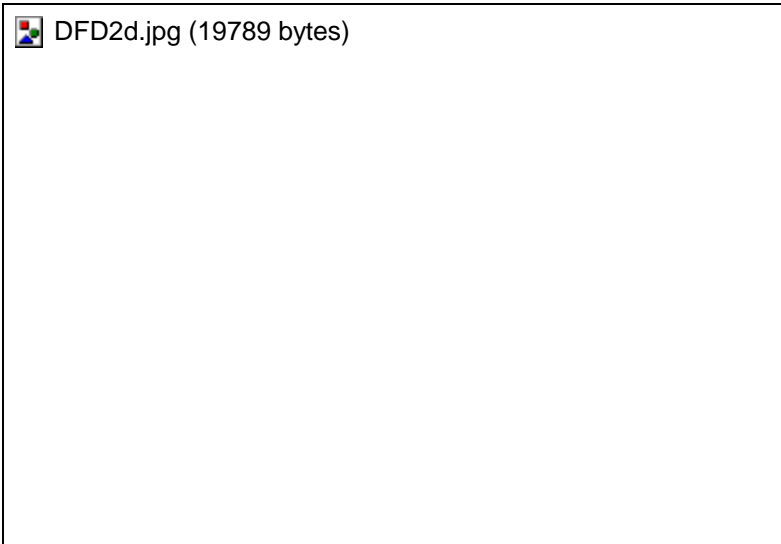
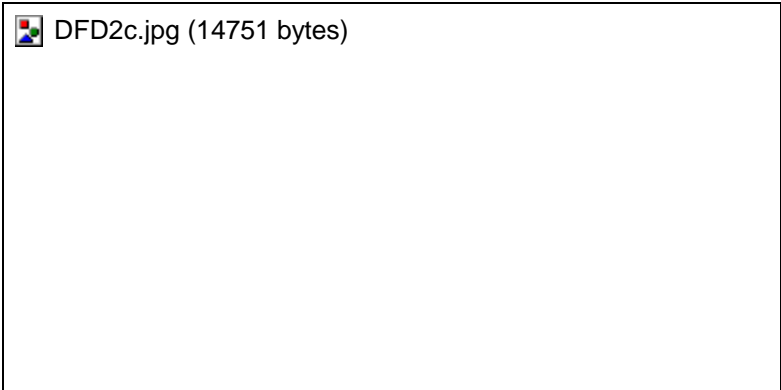

Nex
mou
IC s
and
head

Nex
and
all r
and
back
back
diod

Ther
insta
sold
each
capa

Nex
the 7
volta
regu
the 1
elect
The
turn
trim
are
used

+
Term
of 10
elect
in h
clos
edge
PCE
side
78L
towa
sock

On t
back
of th
insta
sold
10K
cont
cont
the 2
calib
cont

Nex
Insta
ICs

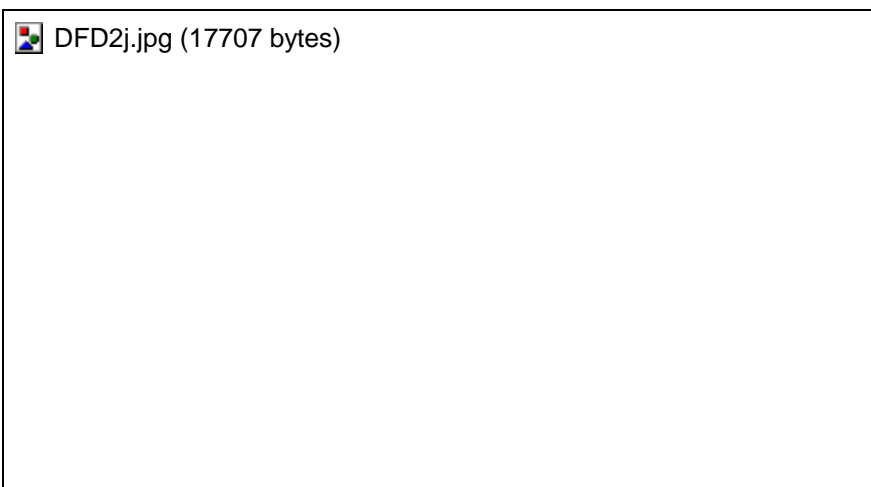
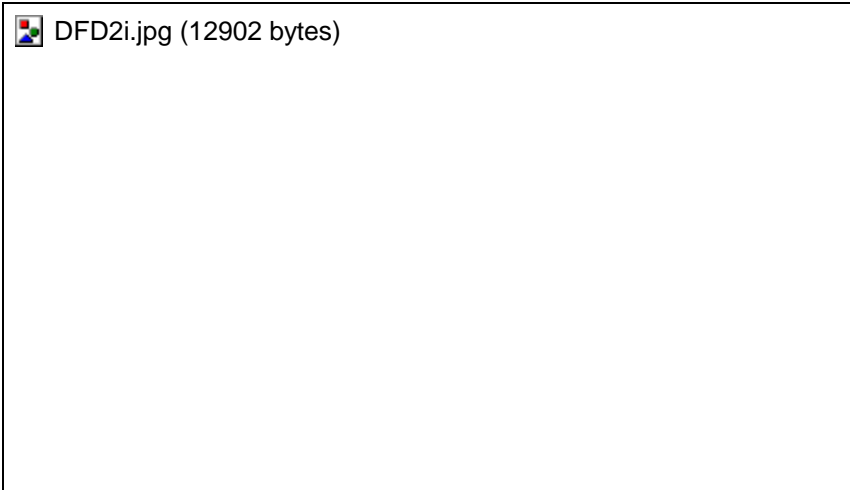

Then solder the remaining pins.

Plug the module into the DFD2 PCB.





At this point you can plug the counter board into the module and power them with a 9 volt battery.

You should see something displayed.

What you see at this point is not important as some inputs are still floating until final assembly in your enclosure. **Set the IF offset by adjusting the 15 turn trimpots. Then install the 74HC4046 chips.**

If only 8 black squares appear, either the TCXO has not been soldered on all 4 points or there is a solder problem on the circuits between the 18 pin chip and the display connector, or on the display module connector.

Backlite

 <p>Green</p>	<p>From a 5volt supply connect 7.5 ohm resistor to pin 15 and ground to pin 16. For higher supply voltages compute resistor $R = (\text{supply voltage} - 4) / \text{current}$</p>
 <p>Blue one line</p>	<p>For a 5Volt supply connect 5V to pin 16, ground to pin 15. Current is 30ma and can be taken from the counter board regulator. For higher supply voltages compute resistor $R = (\text{supply voltage} - 4) / \text{current}$</p>
<p>16 characters customer choice such as: your NAME your CALL SIGN</p>  <p>FREQUENCY and MODE display</p> <p>Blue two line</p>	<p>For a 5Volt supply connect 5V to pin 15, ground to pin 16. Current is 30ma and can be taken from the counter board regulator. For higher supply voltages compute resistor $R = (\text{supply voltage} - 4) / \text{current}$</p>
 <p>Biggy</p>	<p>From a 5volt supply connect 7.5 ohm resistor to pin 15 and ground to pin 16. For higher supply voltages compute resistor $R = (\text{supply voltage} - 4) / \text{current}$</p>
 <p>White</p>	<p>For a 5Volt supply connect 5V to pin 15, ground to pin 16. Current is 30ma and can be taken from the counter board regulator. For higher supply voltages compute resistor $R = (\text{supply voltage} - 4) / \text{current}$</p>

CALIBRATION

- There are many ways to calibrate a frequency counter depending on available test equipment.
- The simplest is to zero beat a signal generator against WWV (receiver bfo off) while measuring the generators frequency with the counter.
 - Adjust the 25 turn trimpot on the back of the PCB to obtain the WWV frequency (20 MHz) on the counter display.
 - Or listen to TCXO on receiver while zero beating it to WWV on 20MHz.
- Any other KNOWN frequency can also be used.

Installation

It is possible to overdrive the inputs causing erratic frequencies to be displayed. A 10K trimpot can be used to set the levels going into the DFD2. the levels should be set only slightly greater than required for a stable display. Set the BFO input first, then the VFO and finally the HFO (usually on 10mtr band).

 pwr conditioning.jpg (37132 bytes)

This is the power conditioning module supplied as part of the plug-n-play fully assembled digital dials. Something similar is recommended for DFD2 applications to provide level controls.

Only one input is required for a DFD1.

The 7805 part is to power a backlit display option.

For additional installation hints see

<http://www.aade.com/applications2/app2.html>

Digital Frequency Display 2

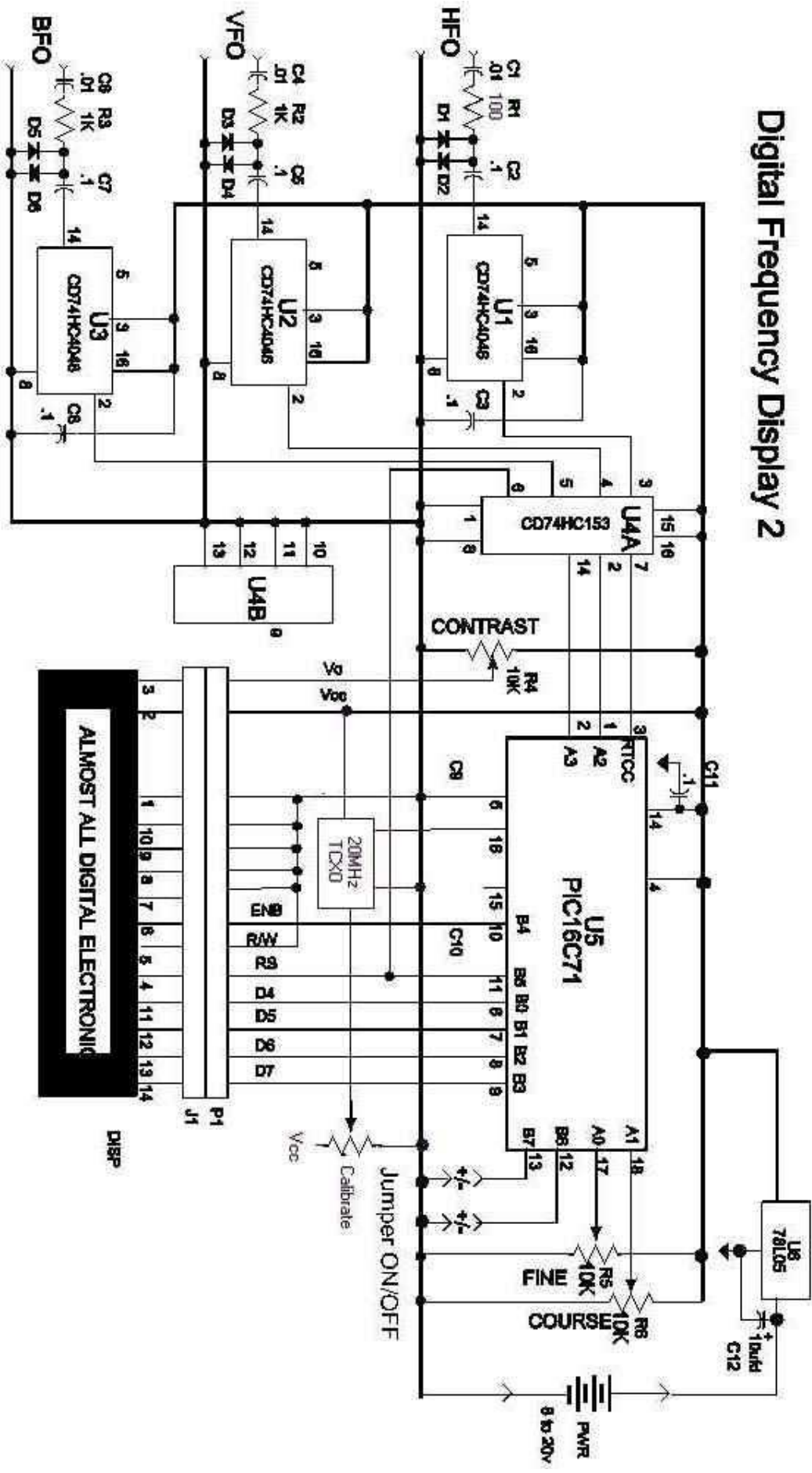

- **FT-101 ([using DFD2-101](#))**

- CONNECTING TO THE FT-101 TRANSCEIVER
- Cabling options:
- 1) You may use the remote VFO plug (octal) if: a. You are sure that you, or anyone else that you may sell the rig to in the future, will never want to install a Yaesu remote VFO; b. You have a spare octal, male plug; c. You are willing to work in a very restricted space. 2) You may bring cables out of the rear of the rig and terminate them with RCA or BNC connectors at the Digital Frequency Display unit if: a. You are not concerned with affecting the resale value of the FT-101 by drilling holes in the rear panel; b. You want to avoid soldering to an octal plug in a very congested location. 3) You may install RCA or BNC chassis mount jacks on the rear panel if: a. You want the modification to appear as inconspicuous as possible; b. You don't want cables that cannot be disconnected at the rear panel; c. You are willing to very accurately measure and drill mounting holes in a very small space.
- Yaesu FT-101 signals
- The BFO signal (3.1793 mhz) is approximately a 3 volt (peak-to-peak) signal that may be tapped in either of two different places. It appears on pin 6 of board 1184A and is carried by a short piece of coaxial cable to pin 5 of board 1183A. Each board has a convenient grounded pin for shield connection, but board 1183A is easier to reach with a small soldering iron.
- After routing the new cable (or mini-coax, which ever you have chosen) from the rear panel to the area of the board chosen, solder a .01 disk ceramic capacitor to the center conductor of the cable. Then solder the free lead of the capacitor to the chosen pin of the board edge connector and the shield to the nearest grounded pin on the edge connector.
- The Local Oscillator signal (approximately 6 mhz above the displayed signal, or 8 to 36 mhz) is approximately a 3 volt (peak-to-peak) signal that is available at the test point near the top edge of board 1181A.
- You have 2 cabling options here. The first option is to route the cable from the rear panel toward the front of the transceiver, and the openings around the tuning dial. Use these openings to pass the cable to the top of the chassis. While viewing the FT-101 from the normal operating position in front of the rig, route this cable up over the tuning shaft and to the right of the chassis. Solder a .01 disk ceramic capacitor to the center conductor and a small ground lug to the shield. Solder the free lead of the capacitor to the test point at the top of board 1181A, and attach the ground lug under the adjacent control's mounting nut and lock-washer.
- CAUTION. This method of installation means that you must disconnect the ground lug in order to remove the board from its edge connector.
- AN ALTERNATIVE installation method is to install the blocking capacitor (.01 disk ceramic) on the board between the test point and unused pin 15. This will allow easy removal of board 1181A. However, it requires soldering the coax to the edge connector for board 1181A in a very congested area. In this alternative installation the cable stays on the underside of the chassis and is soldered to pin 15, with the shield is soldered to pin 18 of the edge connector for board 1181A.
- The VFO signal (approximately 9 mhz) is about a 1 volt (peak-to-peak) signal available at pin 11 of board 1180A. After routing the cable from the rear of the chassis, solder a .01 disk ceramic capacitor to the center conductor. Solder the free capacitor lead to pin 11 and the shield to pin 10 of board 1180A.
- (The VFO signal also appears on the remote VFO adapter (octal) plug. In some versions of FT-101's, this signal does not have enough amplitude to operate the DFD reliably. Your mileage may vary.)
- **Thanks to Stan for supplying this information.**